

WP & ER Series



Walkie & Walkie/Rider Pallet Trucks



From the loading dock to the warehouse, from order picking in a freezer to processing work flow on the factory floor, TCM walkie and walkie/rider pallet trucks help your team work smarter, faster, safer and more productively.

- 6,000 lb./8,000 lb. single/double pallet models
- 5.1 hp DC drive motor (WP models)
- 5.2 hp AC drive motor (ER models)
- Sealed switches and logic boards protected to -20°F
- Multi-function digital indicator readout

Dimensions

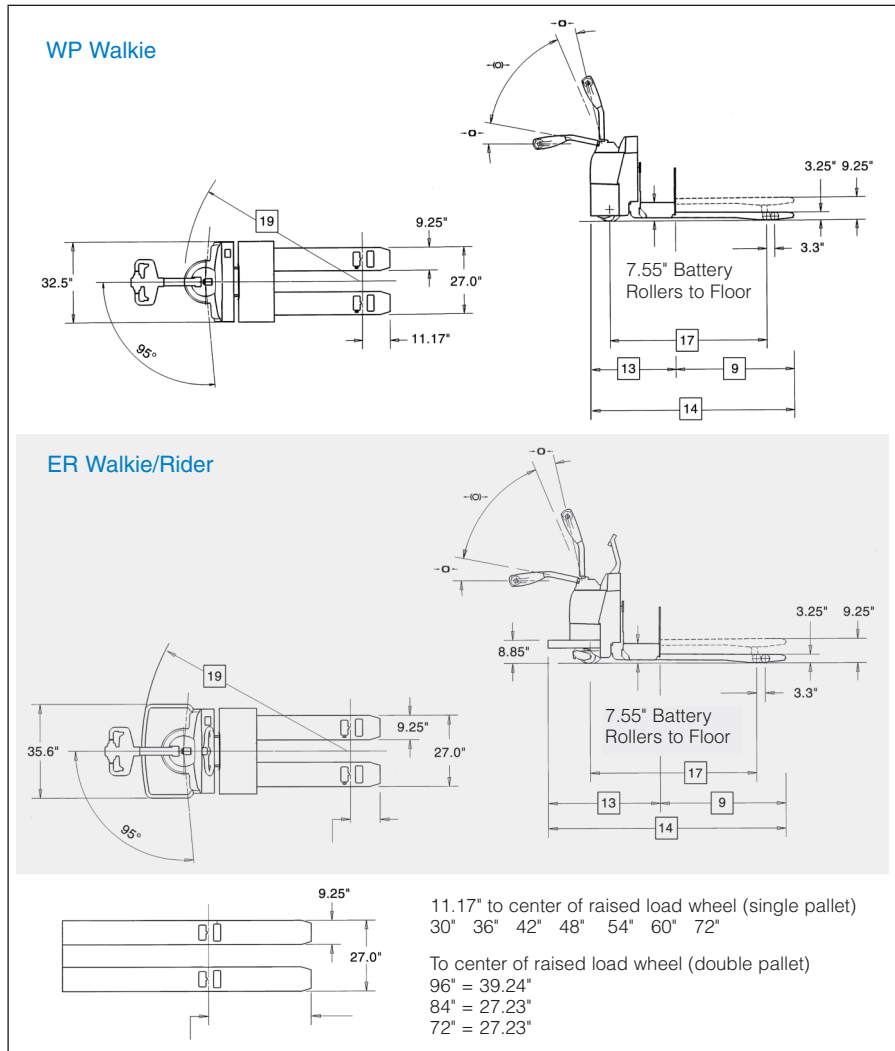

Specifications

WP Walkie		Single Pallet			Double Pallet				
SPECIFICATIONS	9	Nominal Fork Length	in	36	42	48	84	96	9
		Actual Fork Length	in (mm)	35.7 (907)	41.7 (1059)	47.7 (1212)	83.7 (2126)	95.7 (2431)	
	17	Wheelbase (Forks Raised)	in (mm)	51.6 (1311)	57.6 (1463)	63.6 (1615)	83.5 (2121)	83.5 (2121)	17
	18	Grade Clearance	%	36.4	32.5	29.4	22.4	22.4	18
	19	Turning Radius	in (mm)	59.6 (1514)	65.5 (1664)	71.5 (1816)	91.4 (2322)	91.4 (2322)	19
	20	Right Angle Stacking Aisle ^{1,2}							20
		40° Load width	in (mm)	69 (1753)	75 (1905)	81 (2057)	118 (2997)	130 (3302)	
		42° Load width	in (mm)	69 (1753)	75 (1905)	81 (2057)	118 (2997)	130 (3302)	
		48° Load width	in (mm)	68 (1727)	74 (1880)	80 (2032)	118 (2997)	130 (3302)	
		90° Intersecting Aisle ¹							
		40° Load width	in (mm)	56 (1422)	59 (1499)	62 (1524)	74 (1880)	77 (1956)	
		42° Load width	in (mm)	62 (1575)	61 (1549)	64 (1626)	75 (1905)	80 (2032)	
	48° Load width	in (mm)	61 (1549)	64 (1626)	67 (1702)	78 (1981)	87 (2210)		
21	Truck weight	lb (kg)	1012 (459)	1012 (459)	1040 (472)	1179 (535)	1215 (551)	21	

¹ Add 6-8" for ease of operation

² Includes 1" clearance on each side of load

6,000 & 8,000 lb. capacity

Main Truck Specifications

				TCM	TCM	TCM	TCM	
CHARACTERISTICS	1	Manufacturer		TCM	TCM	TCM	TCM	1
	2	Model	Model Designation	WP60	WP80	ER60	ER80	2
	3	Load Capacity	lb (kg)	6000 (2722)	8000 (3629)	6000 (2722)	8000 (3629)	3
	4	Power Type	Electric	24 Volt		24 Volt		4
	5	Operator Type		Walkie		Walkie/Rider		5
	6	Tire Type	Drive Tire	Solid Rubber		Solid Rubber		6
			Load Wheels	Solid Rubber		Poly	High Load Poly	
FORKS	7	Wheels	Number - front/rear	1x/2		1x/2		7
	8	Size	Outside Spread	in (mm) 27 (686)		27 (686)		8
	9		Nominal Length	in (mm) 48 (1219)		48 (1219)	96 (2438)	9
	10	Height	Raised Position	in (mm) 9.25 (234)		9.25 (234)		10
	11		Lowered Position	in (mm) 3.25 (82.6)		3.25 (82.6)		11
	12	Individual Fork Width		in (mm) 9.25 (234)		9.25 (234)		12
	DIMENSIONS	13	Overall Dimensions	Head Length	in (mm) 34.4 (874)		42.9 (1090)	
14		Length with Forks		in (mm) 82.4 (2093)		90.8 (2306)	138.8 (3526)	14
15		Width	Chassis	in (mm) 32.5 (826)		32.5 (826)		15
16			Operator Platform			35.6 (904)		16
17		Wheelbase	Forks Raised	in (mm) 63.6 (1615)		63.6 (1615)	83.5 (2121)	17
18		Grade Clearance	Bottom of Pallet to Floor	%		29.4	22.4	18
19		Turning Radius	Minimum Outside	in (mm) 71.5 (1817)		79.7 (2025)	99.5 (2528)	19
20		Right Angle Stacking ¹	40" x 48" Pallet	in (mm) 81 (2057)		89 (2261)	139 (3531)	20
21		Truck Weight	With Standard Forks	lb (kg) 1040 (472)		1165 (528)	1340 (608)	21
22		Tires / Wheels	Drive Tire	in (mm) 10 x 5 (254 x 127) Rubber		10 x 5 (254 x 127) Rubber		22
23			Load Wheels	in (mm) 3.25 x 6 (83 x 152) Poly		3.25 x 6 (83 x 152) Poly		23
SPEEDS	24	Speed - Travel	No Load	mph (kph) 3.7 (5.9)		9.1 (14.5)		24
	25		Full Load	mph (kph) 3.0 (4.8) 2.6 (4.1)		6.4 (10.3)	6.0 (9.7)	25
	26	Speed - Lift / Lower	Empty	seconds 3.6 / 5.1		3.6 / 5.1		26
	27		Full Load	seconds 5.1 / 4.8 6.1 / 4.7		5.1 / 4.8	6.1 / 4.7	27
BATTERY	28	Max Battery Size	L x W x H	in (mm) 31 x 13.25 x 31.62 (787 x 337 x 803)		32 x 13.5 x 31 (812 x 343 x 787)		28
	29	Amp Hr Capacity	Max (6-hr)	Ah 750		750		29
	30	Weight	Min / Max	lb (kg) 800 / 1500 (363 / 680)		900 / 1500 (408 / 680)		30
	31	Lead Length	Position "B"	in (mm) 20 (508)		20 (508)		31
	32	Connector		type SB-175 Red		SB-175 Red		32

¹ Add 6-8" for ease of operation. Includes 1" clearance on each side of load

Specifications

WB Walkie/Rider			Single Pallet			Double Pallet			
SPECIFICATIONS	9	Nominal Fork Length	in	36	42	48	84	96	9
		Actual Fork Length	in (mm)	35.7 (907)	41.7 (1059)	47.7 (1212)	83.7 (2126)	95.7 (2431)	
	17	Wheelbase (Forks Raised)	in (mm)	51.6 (1311)	57.6 (1463)	63.6 (1615)	83.5 (2121)	83.5 (2121)	17
	18	Grade Clearance	%	36.4	32.5	29.4	22.4	22.4	18
	19	Turning Radius	in (mm)	68.0 (1728)	73.9 (1876)	79.7 (2025)	99.5 (2528)	99.5 (2528)	19
	20	Right Angle Stacking Aisle ^{1,2}							20
		40" Load Width	in (mm)	77 (1956)	83 (2108)	89 (2261)	126 (3200)	139 (3531)	
		42" Load Width	in (mm)	77 (1956)	83 (2108)	89 (2261)	126 (3200)	139 (3531)	
		48" Load Width	in (mm)	77 (1956)	83 (2108)	89 (2261)	126 (3200)	139 (3531)	
		90° Intersecting Aisle ¹							
		40" Load Width	in (mm)	63 (1600)	66 (1676)	68 (1727)	80 (2032)	82 (2083)	
	42" Load Width	in (mm)	64 (1626)	67 (1702)	70 (1778)	81 (2057)	83 (2108)		
	48" Load Width	in (mm)	67 (1702)	70 (1778)	73 (1854)	85 (2159)	86 (2184)		
21	Truck Weight	lb (kg)	1110 (504)	1138 (516)	1165 (528)	1303 (591)	1340 (608)	21	

¹ Add 6-8" for ease of operation

² Includes 1" clearance on each side of load



For information, contact your nearest TCM Dealer.
tcmforklifts.com

TCM America, Inc.
107 McQueen St.
West Columbia, SC 29172